

Syphon tube

Model : A030

Spec. sheet no. AD00-03

Service intended

It is used for protecting the pressure gauge from the effect of hot process media like steam, and it also can reduce the effect of rapid pressure surge.

Standard features

Max. working pressure

Stainless steel

- Code B, C : Up to 25 MPa at 20 °C, G $\frac{1}{4}$ "
(Not available with flange type)
- Code M : Up to 60 MPa at 20 °C, G $\frac{1}{4}$ "

※ This product's Max. working temperature could be varied depending on its working pressure and temperature.

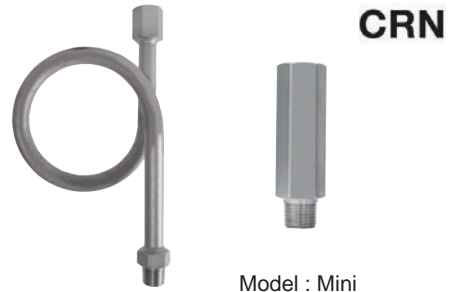

Model : Mini

Main order

Ordering information

1. Base model

A030 Syphon tube

2. Type

- B** Winding
- C** Pig tail
- M** Mini

3. Material

- | | |
|------------------|----------------------|
| C 304SS | H Hastelloy-C |
| D 316SS | I Incoloy |
| F 316L SS | Z Other |
| E 321SS | |

4. Gauge connection size

- | | |
|--------------------------|--------------------------|
| 0 $\frac{1}{4}$ " | 3 $\frac{3}{4}$ " |
| 1 $\frac{3}{8}$ " | 6 1" |
| 2 $\frac{1}{2}$ " | Z Other |

5. Gauge connection type

- A** PF (F)
- B** PT (F)
- C** NPT (F)
- H** NPS (F)
- Z** Other

6. Process connection size

- | | |
|--------------------------|-----------------|
| B $\frac{1}{4}$ " | F 1" |
| C $\frac{3}{8}$ " | Q Flange |
| D $\frac{1}{2}$ " | Z Other |
| E $\frac{3}{4}$ " | |

7. Process connection type

- | | |
|------------------|-----------------------|
| C NPT (F) | N S.W (M) |
| G PF (M) | P Pipe welding |
| H PT (M) | Q Flange |
| J NPT (M) | Z Other |
| M S.W (F) | |

8. Flange size

- | | |
|--------------------------------|----------------------------------|
| A N/A | G 1 $\frac{1}{4}$ " (32A) |
| D $\frac{1}{2}$ " (15A) | H 1 $\frac{1}{2}$ " (40A) |
| E $\frac{3}{4}$ " (20A) | J 2" (50A) |
| F 1" (25A) | Z Other |

9. Flange rating

- | | |
|--------------------------------|------------------------|
| KA N/A | KM JIS 10K RFSF |
| AC B16.5 Class 150 RF | KP JIS 20K RF |
| AE B16.5 Class 150 FF | KR JIS 20K FF |
| AD B16.5 Class 150 RFSF | KQ JIS 20K RFSF |
| AF B16.5 Class 300 RF | KC JIS 30K RF |
| AH B16.5 Class 300 FF | KU JIS 30K FF |
| AG B16.5 Class 300 RFSF | KJ JIS 30K RFSF |
| AJ B16.5 Class 600 RF | KD JIS 40K RF |
| AL B16.5 Class 600 FF | KV JIS 40K FF |
| AK B16.5 Class 600 RFSF | KK JIS 30K RFSF |
| KL JIS 10K RF | ZZ Other |
| KN JIS 10K FF | |

10. Pipe length

- | | |
|--|--|
| 000 $\frac{3}{8}$ " SCH 40 (17.3Ø X 2.3t) | 500 $\frac{3}{4}$ " SCH 80 (27.2Ø X 3.9t) |
| 100 $\frac{3}{8}$ " SCH 80 (17.3Ø X 3.2t) | 600 $\frac{1}{2}$ " SCH 160 (21.7Ø X 4.7t) |
| 200 $\frac{1}{2}$ " SCH 40 (21.7Ø X 2.8t) | 700 $\frac{1}{8}$ " SCH 80 (10.5Ø X 2.4t),
(Only available with pig tail type) |
| 300 $\frac{1}{2}$ " SCH 80 (21.7Ø X 3.7t) | 800 None |
| 400 $\frac{3}{4}$ " SCH 40 (27.2Ø X 2.9t) | |

1	2	3	4	5	6	7	8	9	10
A030	B	C	0	A	B	C	A	KA	000

Sample ordering code

WISE[®]

A030 : Type of mounting (1/3)

Code B

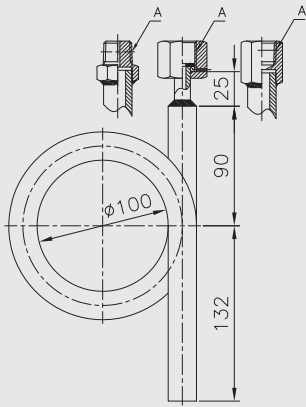

(Pipe Welding)

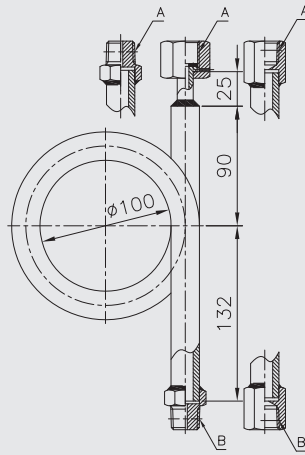

(Thread)

Code C

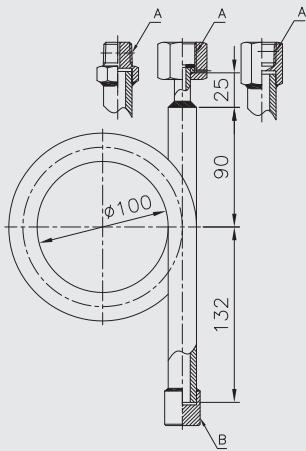
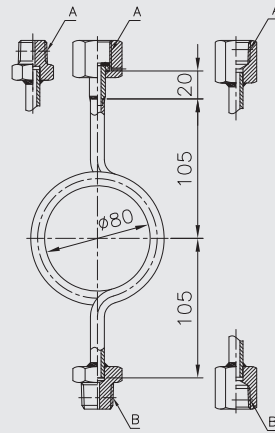

(S.W <M>)

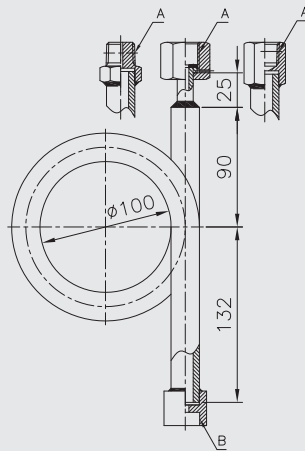

(S.W <F>)

Dimensions (mm)

Type	Pipe		A	B
B	Standard	Size(O.D, thickness)		P.E (M)
	3/8"(8A)	17.14(17.3)	PF 3/8	P.E (F)
	SCH.40, SCH.80	2.31t(2.3t), 3.2t(3.2t)	PF 1/2	PF 3/8
			PT 3/8	PF 1/2
	1/2"(15A)	21.33(21.7)	PT 1/2	PT 3/8
	SCH.40, SCH.80	2.76t(2.9t), 3.73t(3.9t)	NPT 3/8	PT 1/2
C	10.5 X 2.4t		NPT 1/2	NPT 3/8
				NPT 1/2

* NOTE

1. The shown in dimensions when the screw is " PF " type

A030 : Type of mounting (2/3)

Code B

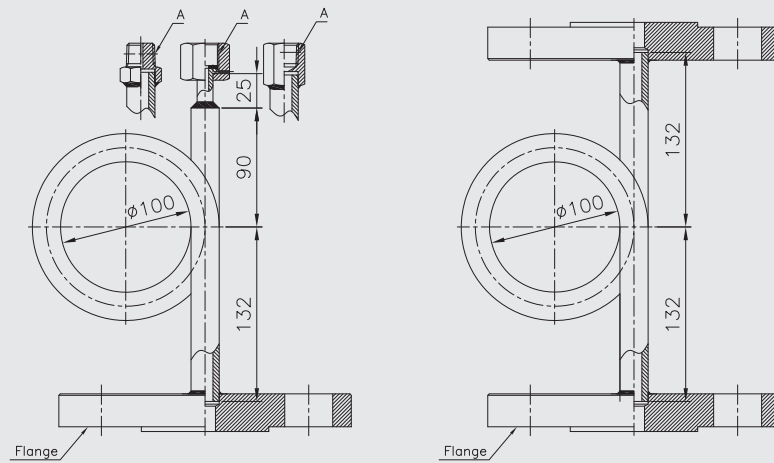

Code C

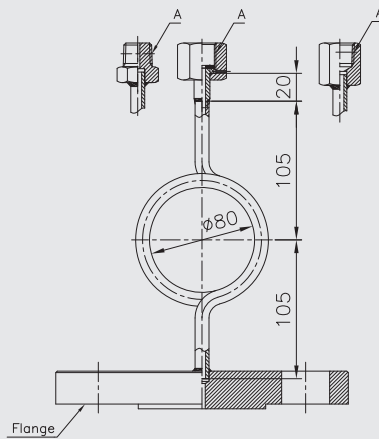

Dimensions (mm)

Type	Pipe		A	Flange rating			
	Standard	Size(O.D, thickness)					
B	3/8"(8A)	φ17.14(φ17.3)	PF 3/8	JIS	10,16,20, 30,40K	15,20,25, 32,40,50A	FF
	SCH.40, SCH.80	2.31t(2.3t), 3.2t(3.2t)	PF 1/2				RF
	1/2"(15A)	φ21.33(φ21.7)	PT 3/8				
	SCH.40, SCH.80	2.76t(2.9t), 3.73t(3.9t)	PT 1/2	B16.5 Class 150, (JPI) 300	1/2,3/4,1, 11/4,11/2,2B	FF	
			NPT 3/8			RF	
C	φ10.5 X 2.4t		NPT 1/2				

* NOTE

1. The shown in dimensions when the screw is " PF " type

A030 : Type of mounting (3/3)

Code M

