

Sanitary thermowell (3-A marking)

Model : A603

Spec. sheet no. AD06-02

Service intended

A603 thermowell for temperature sensor and temperature gauge are recommended for all process systems where pressure, velocity, viscous, abrasive, and corrosive materials are present individually or in combination. A properly selected thermowell will protect the temperature instrument from possible damage resulting from these process variables. Furthermore, thermowell permits removal of the temperature instrument for replacement, repair, or testing without effecting the process media or the system.



Standard features

Process connection

Tri-clamp connection
1S, 1½S and 2S

Gauge connection

½" (N)PT, female

Bore diameter

7, 9, 10 and 12 mm

Material

304SS, 316SS and 316L SS

Surface finish

Max. Ra 32 µin. (0.8 µm)

Main order

Ordering information

1. Base model

A6030 Sanitary thermowell (3-A marking)

2. Material

EX 316LSS
CX 316SS
BX 304SS
DX 304L SS

3. Internal connection

0 ½" NPT
1 ½" PT

4. Tip outer diameter / Bore size (mm)

A0 14 / 7	C2 17 / 10
A1 14 / 9	C3 17 / 12
B0 16 / 7	D0 19 / 7
B1 16 / 9	D1 19 / 9
B2 16 / 10	D2 19 / 10
C0 17 / 7	D3 19 / 12
C1 17 / 9	D4 21 / 10

5. Process connection size

C 1"
E 1½"
F 2"

6. Process connection type

4 Tri-clamp

7. Insertion length ("U") length (mm)

0 80	8 450
1 100	A 500
2 150	B 600
3 200	C 700
4 250	D 800
5 300	E 900
6 350	F 1,000
7 400	Z Other

Note : Please choose a code of next higher length if applicable length is not.
 Actual length shall be specified.

8. "T" length (mm)

0 45
1 50 below
2 50 above

Note : Actual length shall be specified.

9. Option

0 None
1 Plug and chain (304SS)
2 Plug and chain (316SS)

1	2	3	4	5	6	7	8	9	Sample ordering code
A6030	EX	0	A0	C	4	1	1	1	

A603 : Standard product drawing

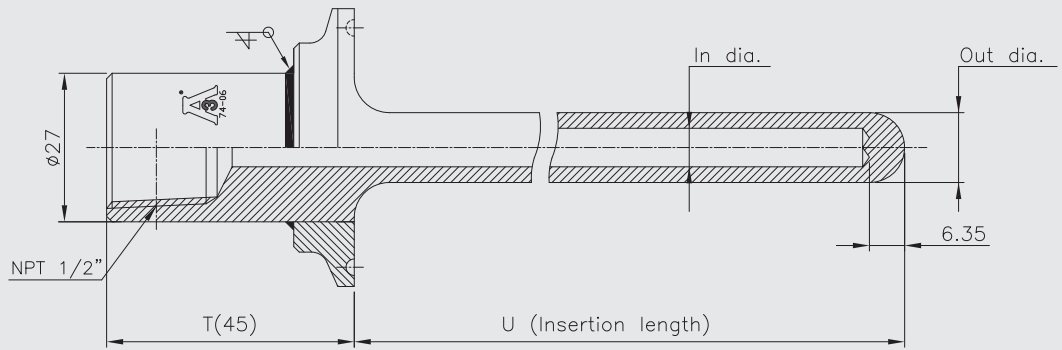

A large empty rectangular box with a thin black border, intended for writing a memo.