

Integral flow orifice assembly

Model : F510

Spec. sheet no. FD05-02

Description

Integral orifice primary element utilizes a self centering orifice plate design to eliminate installation error. Enables highly accurate flow measurement in small line sizes. Available with a variety of process connections. Available in ½" to 1½" (15 ~ 40 mm) line sizes.



Principle

- Improves accuracy and repeatability
- Self-centering plate design eliminates installation errors that are magnified in small line sizes
- Precision honed pipe sections allow accuracy of up to $\pm 0.75\%$ of flow rate
- Installation flexibility with numerous process connections

Specification

Line size

Liquid : ½" (15 mm)

Gas : 1" (25 mm)

Steam : 1½" (40 mm)

- Maximum working pressure :
Pressure retention per ANSI B16.5 600 Lb or DIN PN100

Gaskets / O-rings

Glass filled PTFE

Orifice plate

316SS / 316L SS

Alloy C-276

Alloy 400

Orifice type

Square edge-orifice bore sizes

Body

316SS (CF8M), Material per ASTM A351

Pipe material (If applicable)

A312 Gr 316SS / 316L SS

B622 UNS N10276

Alloy C-276

Transmitter connections

2½" (54 mm) center to center.

Other transmitter spacing can be accommodated using the optional remote adapters and customer supplied impulse piping. DIN 19213 connections are available

Flange

A182 Gr 316SS / 316L SS

SB-564 UNS N10276

Alloy C-276

- Flange pressure limits are per ANSI B16.5
Flange face finish per ANSI B16.5, 125 to 250 RMS

Note

Integral orifice bodies contain corner tapped pressure ports.

Body bolts / Studs

ASTM A 193 Gr B8M studs

1. Base model**F510** Integral flow orifice assembly**2. Body material**

S 316SS (A351 CF8M)
T 304SS (A351 CF8)
H Hastelloy-C (A494 CW12MW)
O Others

3. Line size

1 ½" (15 mm)
2 ¾" (20 mm)
3 1" (25 mm)
4 1½" (40 mm)

4. Pipe ends

01 JIS 10K SORF	12 ANSI 600 Lb SORF
02 JIS 20K SORF	13 ANSI 150 Lb WNRF
03 JIS 30K SORF	14 ANSI 300 Lb WNRF
04 JIS 10K WNRF	15 ANSI 600 Lb WNRF
05 JIS 20K WNRF	16 ANSI 150 Lb RTJ
06 JIS 30K WNRF	17 ANSI 300 Lb RTJ
07 JIS 10K RTJ	18 ANSI 600 Lb RTJ
08 JIS 20K RTJ	20 NPT threaded
09 JIS 30K RTJ	21 Beveled
10 ANSI 150 Lb SORF	22 Others
11 ANSI 300 Lb SORF	

5. Orifice plate material

S 316L SS
H Hastelloy-C
M Monel
O Other

6. Mounting

D Direct
R Remote

7. Option

D DP transmitter
F Flow calibration
M 3 or 5 way manifold valve
N None

1	2	3	4	5	6	7
F510	S	1	10	S	D	D

Sample ordering code

Dimensional drawing

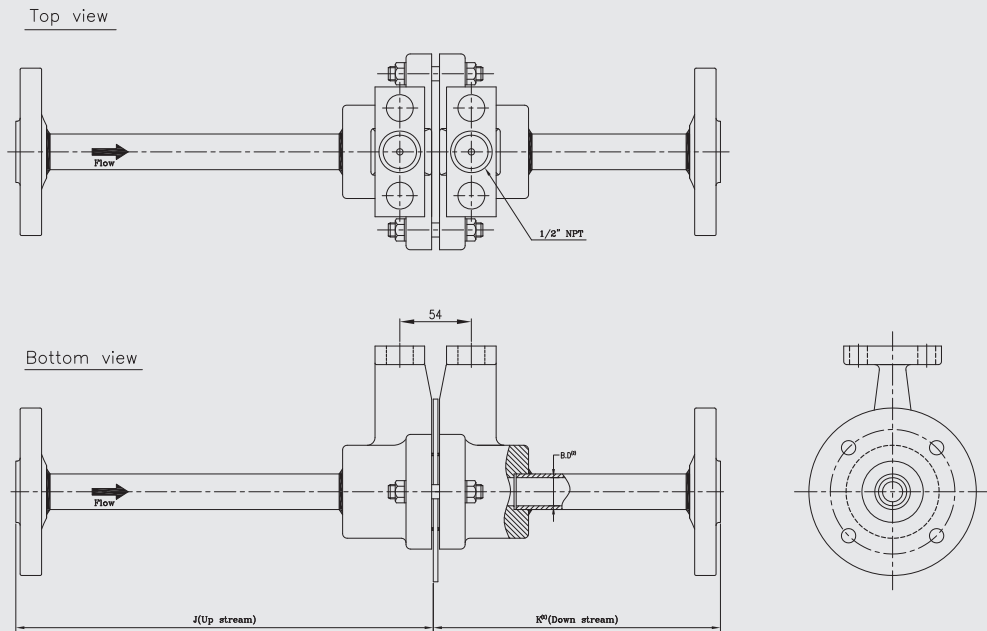

Table1. Integral orifice plate dimensional data

Dimension	Line size					
	1/2"	12.7 mm	1"	25.4 mm	1 1/2"	38.1 mm
J (Beveled / Threaded pipe ends)	12.54"	318.4 mm	20.24"	514.0 mm	28.44"	722.4 mm
J (RF slip-on, RTJ slip-on, RF-DIN slip-on)	12.62"	320.4 mm	20.32"	516.0 mm	28.52"	724.4 mm
J (RF150#, weld-nect)	14.37"	364.9 mm	22.37"	568.1 mm	30.82"	782.9 mm
J (RF300#, weld-nect)	14.56"	369.8 mm	22.63"	574.7 mm	31.06"	789.0 mm
J (RF600#, weld-nect)	14.81"	376.0 mm	22.88"	581.0 mm	31.38"	797.1 mm
K (RF slip-on, RTJ slip-on, RF-DIN slip-on) ⁽¹⁾	5.82"	147.8 mm	8.83"	224.2 mm	11.99"	304.6 mm
K (RF150#, weld-nect)	7.57"	192.3 mm	10.88"	276.3 mm	14.29"	363.1 mm
K (RF300#, weld-nect)	7.76"	197.1 mm	11.14"	282.9 mm	14.53"	369.2 mm
K (RF600#, weld-nect)	8.01"	203.4 mm	11.39"	289.2 mm	14.85"	377.2 mm
B.D. (Bore diameter) ⁽²⁾	0.664"	16.86 mm	1.097"	27.86 mm	1.567"	39.80 mm

(1) Downstream length shown here includes plate thickness of 0.162" (4.11 mm)

(2) B.D. is diameter of the precision bored portion of the upstream and downstream piping.

Dimension

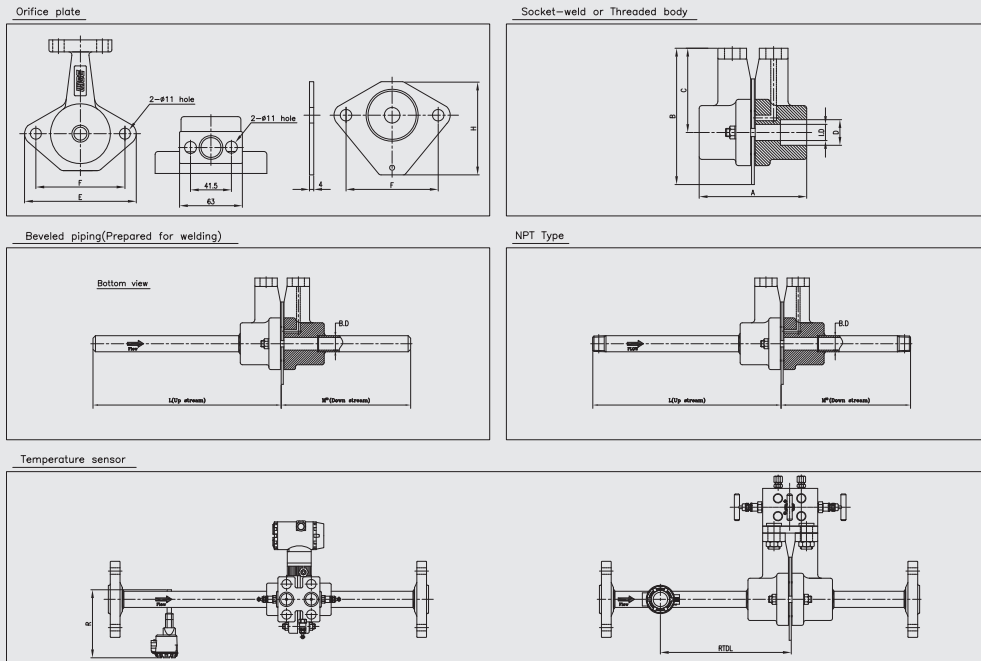

Table2. Integral orifice plate dimentional data

Dimension	Line size					
	½"	15 mm	1"	25 mm	1½"	40 mm
A	3.4"	86 mm	3.8"	97 mm	4.5"	114 mm
B	4.7"	119.4 mm	5.2"	132 mm	5.9"	149.9 mm
C	3.0"	76 mm	3.3"	84 mm	3.7"	94 mm
D ⁽¹⁾	0.805"	20.45 mm	1.280"	32.51 mm	1.865"	47.37 mm
E	3.6"	91.66 mm	3.9"	99 mm	4.4"	112 mm
F	2.6"	66 mm	3.0"	76 mm	3.5"	89 mm
H	2.5"	64 mm	3.0"	76 mm	3.5"	89 mm
L	12.54"	318.4 mm	20.24"	514 mm	28.44"	722.4 mm
M	5.74"	145.7 mm	8.75"	222.2 mm	11.91"	302.6 mm
R	7.4"	187.96 mm	7.8"	198.12 mm	8.4"	213.36 mm
RTDL	3.11"	78.9 mm	5.25"	133.4 mm	7.50"	190.5 mm
B.D. (Bore diameter) ⁽²⁾	0.664"	16.87 mm	1.097"	27.86 mm	1.567"	39.80 mm
I.D. (Inside diameter)	0.622"	15.80 mm	1.049"	26.64 mm	1.500"	38.10 mm

- (1) To improve pipe perpendicularity for gasket sealing, socket diameter "D" is smaller than standard pipe O.D. Pipe O.D. must be machined smaller than socket diameter "D" to ensure proper fit.
 (2) B.D is diameter of the precision bored portion of the upstream and downstream piping.

Determination of differential pressure and orifice bore

Differential pressure

To calculate exact differential pressure produced at known flow rate, use one of the following equations:

$$\text{Liquid : } h = \text{gf} \left[\frac{q(\text{in U.S. qpm})}{5.668 \times Fa \times Fpv \times K \times d^2} \right]^2$$

$$\text{Gas : } h = \frac{GT_f}{P_f} \left[\frac{Q(\text{in scfh})}{7727 \times Fa \times Fpv \times K \times d^2 \times Y} \right]^2$$

$$\text{Steam : } h = V \left[\frac{W(\text{lb/hr})}{359 \times Fa \times K \times d^2 \times Y} \right]^2$$

d = Bore diameter in inches

Fa = Thermal expansion factor of orifice plate

G = Specific gravity of gas

Gf = Specific gravity of liquid at flow conditions

h = Differential pressure in in.H₂O

K = Flow coefficient

Pf = Process pressure in psia (psig + 14.7)

Q = Flow rate of gas

q = Flow rate of liquid

Tf = Process temperature in °R (°F + 460)

V = Specific volume of steam in cu ft/Lb

W = Flow rate of steam

Y = Gas expansion factor

Fpv = Gas super compressibility $Fpv = \sqrt{\frac{Zb}{ZF}}$

Zb = Basic compressibility

ZF = Flowing compressibility

Large empty rectangular area for writing the memo content.