

# General service pressure gauge with economic design diaphragm seal

## Model : P170 series

Spec. sheet no. PD01-07

### Service intended

P170 series are designed to withstand corrosive, contaminated, or heterogeneous pressure media by employing the welded bellows. Especially, it can be used for water treatment process machines and sludge water lines.

ERC

### Nominal diameter

75 and 100 mm

### Accuracy

±1.5 % of full scale

### Scale range (MPa, kPa, bar)

-0.1 ~ 0 to 0 ~ 2.5 MPa

### Working pressure

Steady : 75 % of full scale

Over range protection : 130 % of full scale

### Working temperature

Ambient : -20 ~ 65 °C

Fluid : Max. 100 °C

### Special features

Design with internal diaphragm, upper and lower housing welded

Excellent cost-performance ratio

### Temperature effect

Accuracy at temperature above and below the reference temperature (20 °C) will be effected by approximately ±0.4 % per 10 °C of full scale



## Standard features

### Pressure connection

Upper and Under flange : 304SS

### Movement

Brass

### Element

Diaphragm : 316L SS

### Pointer

Black painted aluminium alloy

### Case

Black painted steel

### Process connection

¼" PT, NPT and PF

⅜" PT, NPT and PF

### Cover

Black painted steel

### Window

Glass

### Option

Dial size : 60 and 75 mm

Another process connection size and type

**WISE**<sup>®</sup>

**1. Base model**

**P170** General service pressure gauge with screwed diaphragm seal assembly

**2. Nominal diameter (mm)**

- 3 75
- 4 100

**3. Type of mounting**

- A Bottom connection, direct
- F Center back connection, direct

**4. Accuracy**

- 4 ±1.5 % of full scale

**5. Process connection**

- C ¼"
- D ⅜"

**6. Connection type**

- B PF
- C PT
- D NPT

**7. Unit**

- H bar
- I MPa
- J kPa

**8. Range**

**XXX** Refer to pressure unit and range table

**9. Dial color**

- 1 2 colors
- 5 3 colors

**10. Option**

- 0 None
- 1 Accessories

1	2	3	4	5	6	7	8	9	10
P170	4	A	4	D	C	H	XXX	1	0

Sample  
ordering code

## P170 : Type of mounting

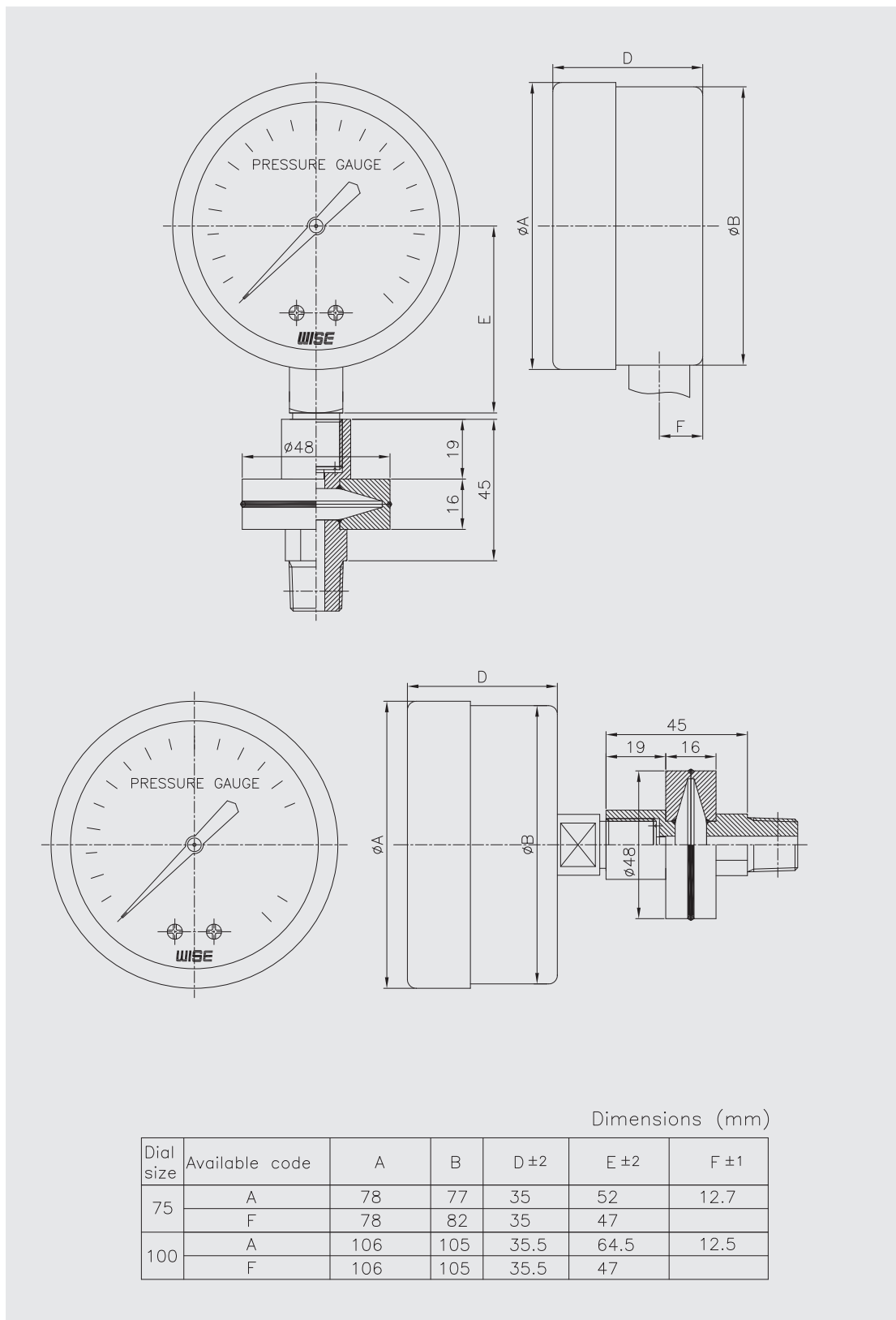

Dimensions (mm)

Dial size	Available code	A	B	D ±2	E ±2	F ±1
75	A	78	77	35	52	12.7
	F	78	82	35	47	
100	A	106	105	35.5	64.5	12.5
	F	106	105	35.5	47	

## Pressure unit and range table

Range and code	Unit and code			75 mm	100 mm
	H : bar	I : MPa	J : kPa		
042	0 ~ 2	0 ~ 0.2	0 ~ 200	O	O
043	0 ~ 3	0 ~ 0.3	0 ~ 300	O	O
044	0 ~ 4	0 ~ 0.4	0 ~ 400	O	O
045	0 ~ 6	0 ~ 0.6	0 ~ 600	O	O
047	0 ~ 10	0 ~ 1	0 ~ 1,000	O	O
050	0 ~ 15	0 ~ 1.5	X	O	O
051	0 ~ 20	0 ~ 2	X	O	O
052	0 ~ 25	0 ~ 2.5	X	O	O
028	-1 ~ 2	-0.1 ~ 0.2	-100 ~ 200	O	O
029	-1 ~ 3	-0.1 ~ 0.3	-100 ~ 300	O	O
030	-1 ~ 4	-0.1 ~ 0.4	-100 ~ 400	O	O
031	-1 ~ 6	-0.1 ~ 0.6	-100 ~ 600	O	O
032	-1 ~ 10	-0.1 ~ 1	-100 ~ 1,000	O	O
033	-1 ~ 15	-0.1 ~ 1.5	-100 ~ 1.5 MPa	O	O
034	-1 ~ 20	-0.1 ~ 2	-100 ~ 2 MPa	O	O

O : Available X : Not available