

# Ball type sight glass

## Model : S300 series

Spec. sheet no. SD03-01

### Description

Sight glass with balls can check the fluid flow by observing motion of balls.

### Model : S300

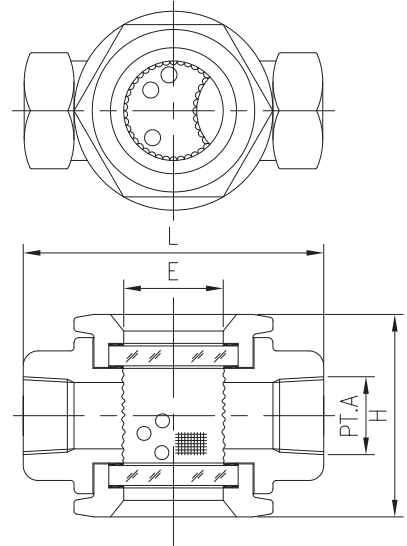
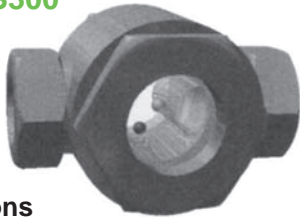

### Connections

Screwed end

### Max. pressure

2.9 MPa

### Max. temperature

100 °C

### Glass

Tempered

### Body material

A216 WCB

A351 CF8

A351 CF8M

A106 Gr.B

### Dimension

Size A(")	L	H (Approx.)	E
8 (¼)	120	105	50
10 (¾)	120	105	50
15 (½)	120	105	50
20 (¾)	120	105	50
25 (1)	140	115	50
32 (1¼)	160	130	65
40 (1½)	160	130	65
50 (2)	180	140	80

### Model : S310

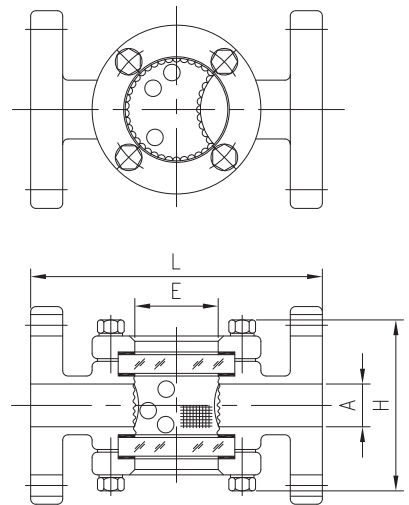
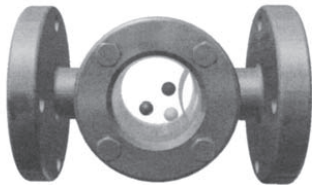

### Connections

Flanged end

### Max. pressure

2.9 MPa

### Max. temperature

100 °C

### Glass

Tempered

### Body material

A216 WCB

A351 CF8

A351 CF8M

A106 Gr.B

### Dimension

Size A(")	L	H (Approx.)	E
15 (½)	155	125	40
20 (¾)	155	125	40
25 (1)	170	135	50
32 (1¼)	200	155	65
40 (1½)	200	155	65
50 (2)	220	170	75
65 (2½)	270	205	105
80 (3)	270	205	105
100 (4)	320	235	130
125 (5)	380	280	170
150 (6)	420	330	200
200 (8)	500	380	260

**1. Base model**

<b>S300</b>	Ball type (Screwed) sight glass
<b>S310</b>	Ball type (Flanged) sight glass

**2. Line size**

JIS	mm	ANSI	inch	DIN	mm
<b>J015</b>	15A	<b>A001</b>	½B	<b>D015</b>	15A
<b>J020</b>	20A	<b>A002</b>	¾B	<b>D020</b>	20A
<b>J025</b>	25A	<b>A003</b>	1B	<b>D025</b>	25A
<b>J040</b>	40A	<b>A004</b>	1½B	<b>D040</b>	40A
<b>J050</b>	50A	<b>A005</b>	2B	<b>D050</b>	50A
<b>J065</b>	65A	<b>A006</b>	2½B	<b>D065</b>	65A
<b>J080</b>	80A	<b>A007</b>	3B	<b>D080</b>	80A
<b>J100</b>	100A	<b>A008</b>	4B	<b>D100</b>	100A
<b>J125</b>	125A	<b>A009</b>	5B	<b>D125</b>	125A
<b>J150</b>	150A	<b>A010</b>	6B	<b>D150</b>	150A
<b>J200</b>	200A	<b>A011</b>	8B	<b>D200</b>	200A
		<b>OXXX</b>	Other		

**3. Glass material**

<b>T</b>	Tempered
<b>O</b>	Other

**4. Flange rating code**

JIS		ANSI		PN	
<b>J010</b>	JIS 10K	<b>A010</b>	ANSI 150 Lb	<b>P010</b>	10 bar
<b>J020</b>	JIS 20K	<b>A020</b>	ANSI 300 Lb	<b>P016</b>	16 bar
<b>XXXX</b>	None	<b>OXXX</b>	Other		

**5. Screwed connection**

<b>A</b>	NPT (F)
<b>J</b>	PT (F)
<b>N</b>	None

**6. Gaskets material**

<b>N</b>	Non-asbestos
<b>T</b>	Teflon
<b>O</b>	Other

**7. Body material**

<b>C</b>	Carbon steel (A216 WCB)
<b>4</b>	304SS (A351 CF8)
<b>6</b>	316SS (A351 CF8M)
<b>O</b>	Other

1	2	3	4	5	6	7
<b>S300</b>	<b>A007</b>	<b>T</b>	<b>A010</b>	<b>N</b>	<b>T</b>	<b>4</b>

Sample ordering code