

Absolute pressure transmitter

Model: SMT2003

Spec. sheet no. SD02-03

Service intended

The high performance pressure transmitter SMT2003 is suitable to measure liquid, gas, or steam flow as well as liquid level, density and pressure.

The key features include quick response, remote set-up using communications, self-diagnostics and optional status output for pressure high/low alarm.



Standard features

Accuracy

±0.05 % of calibrated span
±0.075 % of calibrated span

Range limits

40 kPa ~3 MPa

Turn down

Adjustable up to 100:1 range ability

Temperature compensation

High sensitivity temperature sensor packaged in the sensor

Isolating diaphragm

Stainless steel 316L
Hastelloy C
Stainless steel 316L with Gold Plated

Measurement medium

Gas, Steam and liquid

Stability

10 years stability
0.15 % of URL

Output

4 ~ 20 mA with HART protocol

WISE[®]

I SMT2003_01

Principle of operation

Main unit includes sensor and Process connection, Works as follows.

The process medium through a flexible, corrosion resistance of the isolation diaphragm and the fill fluid pressure is applied on the measuring silicon pressure chip.

A termination of the chip connected at the atmosphere (for a gauge pressure measurement) or vacuum (for absolute pressure measurement).

The absolute pressure sensor, which is only exposed to the pressure at the high pressure side, acts as a reference value to compensate for the static pressure.

The temperature sensor as a temperature compensated reference value to compensate for the temperature drift.

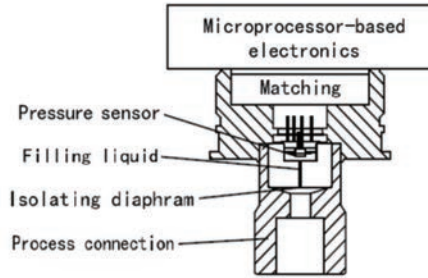

Main specification

- The gauge pressure transmitter utilize the world's leading high stability silicon sensor, the highest Reference Accuracy is $\pm 0.05\%$
- High sensitivity temperature sensor packaged in the sensor. The minimum of the temperature error is $\leq \pm 0.05\% / 10\text{ K}$
- Stainless steel 316L and silicone oil filling welded seal structure
- Long stability is $\leq \pm 0.1\%$ / 3 years, 10 years of maintenance-free
- Adjustable up to 100:1 range ability
- The remote seal transmitter utilize ultra-high temperature(400 °C) patented technology.

Standard Specifications

Performance Specifications

Reference Accuracy of Calibrated Span (includes terminal-based linearity, hysteresis, and repeatability) $\pm 0.075\%$
If $TD > 10(TD = URL / SPAN)$, $\pm(0.005 \times TD)\%$

The square root accuracy is 1.5 times of reference accuracy of calibrated span.

Ambient Temperature Effects

-20 ~ 65 °C : $\pm(0.2 \times TD + 0.05)\% \times \text{Span}$

Every 10 °C is $\pm 0.08\% \times \text{Span}$ (TD=1)

-40 ~ -20 °C and 65 ~ 85 °C : $\pm(0.3 \times TD + 0.1)\% \times \text{Span}$

Overpressure Effects

$\pm 0.075\% \times \text{Span}$

Stability

$\pm 0.1\% \times \text{Span} / 3 \text{ years}$

Power Supply Effects

$\pm 0.001\% / 10 \text{ V}$ (12 ~ 42 V DC)

Explosion protection

Ex db IIC T4 / T5 / T6 Gb

Ex tb IIIC T80 °C / T90 °C / T130 °C Db

Ta = -40°C to +60 °C

Ex d IIC T6

Temperature class Max. process temperature

T4 T130 °C 130 °C

T5 T90 °C 90 °C

T6 T80 °C 80 °C

Functional Specifications

Span and Range Limits

Sensor	C	D	E
Pressure range (bar)	400 mbar	2.5 bar	30 bar
Setting limits (offset and span in this range freely adjustable)	0 ... 400 mbar	0 ... 2.5 bar	0 ... 30 bar
Lowest permissible span	20 mbar	25 mbar	0.3 bar
Overpressure limit	10 bar	40 bar	150 bar
Range ability turndown (with respect to the differential pressure range)	20:1	100:1	100:1

Turn-down Accuracy

If the Accuracy is (%): 0.075

Turn-down $\leq 10:1 \leq \pm 0.075\% \text{ FSO}$

Turn-down $> 10:1 \leq \pm[0.075 \times \text{Turn-down}]\% \text{ FSO} \pm 0.075\%$

Turn-down = Nominal Pressure Range / Adjusted

Zero Adjustment Limits

Zero can be fully elevated or suppressed, within the lower and upper range limits of the capsule.

Standard Specifications

External Zero Adjustment

External zero is continuously adjustable with 0.01 % incremental resolution of span. Re-range can be done locally using the range setting switch.

Mounting Position Effects

Rotation in diaphragm plane has no effect. Tilting up to 90° will cause zero shift up to 0.25 kPa which can be corrected by the zero adjustment.

Output

2 wire 4~20 mADC output with digital communications, linear or square root programmable. HART FSK protocol are superimposed on the 4~20 mA DC signal. Output range: 3.9 mA to 20.5 mA.

Failure Alarm (the mode can be selected)

Low Alarm Mode (min) : 3.7 mA
High Alarm Mode (max) : 21 mA
Alarm Off (Keep) : Keep the effective value before the fault.

* Compliant with NAMUR NE-43

* Note : The standard setting of failure alarm is High Mode.

Response Time

The amplifier damping constant is 0.1 sec.

The sensor damping constant is 0.1~1.6 sec, it depends on the range and range compression ratio.

Amplifier damping time constant is adjustable from 0.1 to 60 sec by software and added to response time.

Warm Up Time

< 15s

Permissible Temperatures

Environment / storage without display : -40 to 85 °C
with display : -20 to 65 °C

Media wetted parts / Filled oil : -40 to 100 °C
(Info: +125°C short time, max. 30 min.)

Standard Specifications

HART digital communication and 4 to 20 mA output Power Supply

The transmitter operates from 12 to 42 V DC with no load and is protected against reverse polarity connection
Minimum operating voltage increase to 12 V DC with surge protector

Ripple

20 mV max on a 250 Ω load as per HART specifications.

Load limitations

4 to 20 mA and HART total loop resistance :

$$R \text{ (k}\Omega\text{)} = \frac{\text{Supply voltage} - \text{min. operating voltage (V DC)}}{22 \text{ mA}}$$

A minimum of 250 Ω is required for HART communication.

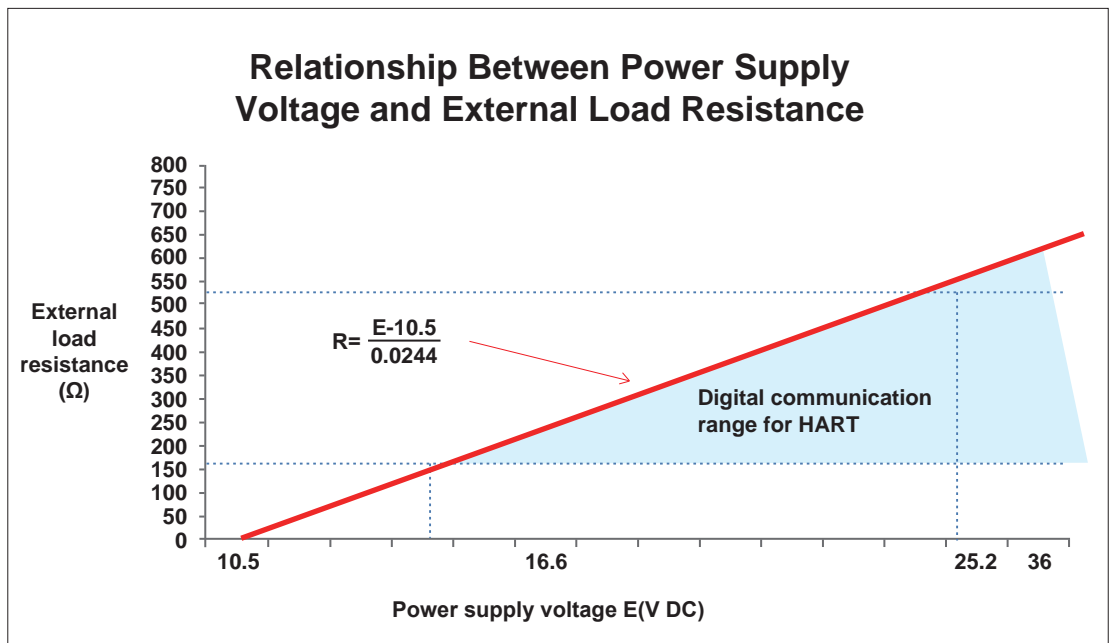

Supply and Load Requirements

24 VDC supply, $R \leq (U_s - 12 \text{ V}) / I_{\text{max}}$ kΩ, $I_{\text{max}} = 23 \text{ mA}$.

Maximum voltage limited: 42 VDC

Minimum Voltage limited: 12 VDC without LCD display

Minimum Voltage limited: 15 VDC with LCD display

250 Ω to 600 Ω for digital communication

Electrical protection

Short-circuit protection is permanent.

Reverse polarity protection is not damage, but also is no function.

Electrical Connection

The electrical connection is made via cable entry M20x1.5.

The screw terminals are suitable for wire cross-sections up to 2.5 mm².

Standard Specifications

Process Connection

Default Process Connection : ½ NPT female thread

Electromagnetic field

Meets all the requirements of EN 61326 and NAMUR NE-21. it can be changed to ½ NPT, G½, M20x1.5 male thread and KF16 vacuum Connection

Load

Within load/voltage specified limits the total effect is negligible

Install

The transmitter housing can be rotated about 360 degrees relative to the transmitter module without affecting the performance and internal wiring.

Transmitter can be operated Through the PC machine or notebook computer via modem.

Modem can be connected in parallel to the signal circuit at arbitrary point.

The modem communicates with the transmitter through an AC signal superimposed on the 4~20 mA output signals.

This modulation does not change in the mean values, so does not affect the measurement signal.

Physical Specifications

Isolating Diaphragm

Stainless steel 316L

Hastelloy C

Stainless steel 316L with Gold Plated

Mounting Bracket

stainless steel 304

Carbon steel galvanized

Process Connection

½" NPT (Female)

½" NPT (Male) with Union

M20 x 1.5P (male) with Union

G ½" (male) with Union

DIN 28403 KF16 / ISO 2861

¼" NPT (male) with Union

Others

Conduit Connection

M20 x 1.5

Name plate and tag

Stainless steel 304

Weight

1.6 kg

Fill fluid

Silicone oil / Fluorinated oil

Degrees of Protection

IP66/IP67

Amplifier Housing

Aluminium with epoxy resin coat

Stainless steel 316

CE conformity EMC directive

EN 61000-6-2:2005

EN 61000-6-4:2007/A1:2011

2" MOUNTING TYPE

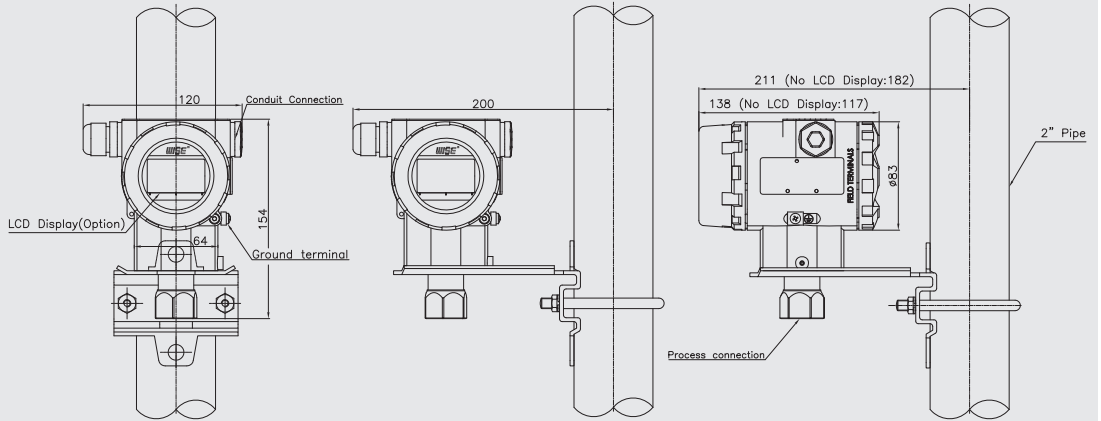

WALL MOUNTING TYPE

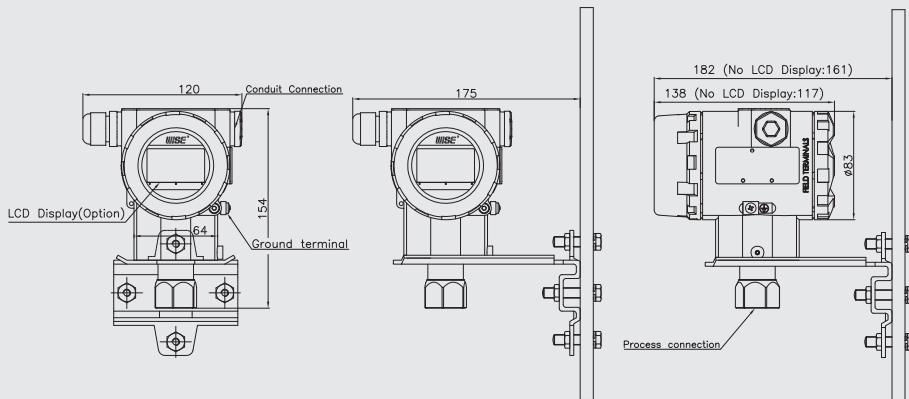

Process Connections Description Default Process Connection

B/C/D Span

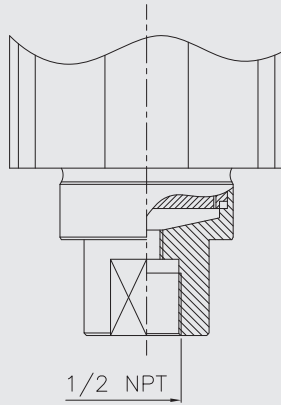

SMT2002 A

E/F/G/H Span

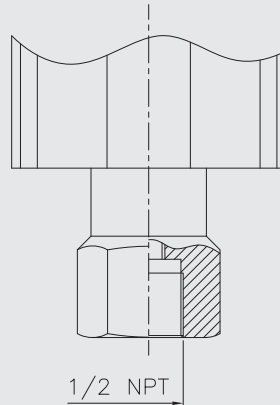

SMT2002 B

Local Set Button

Magnetic button
Component (Two in one)

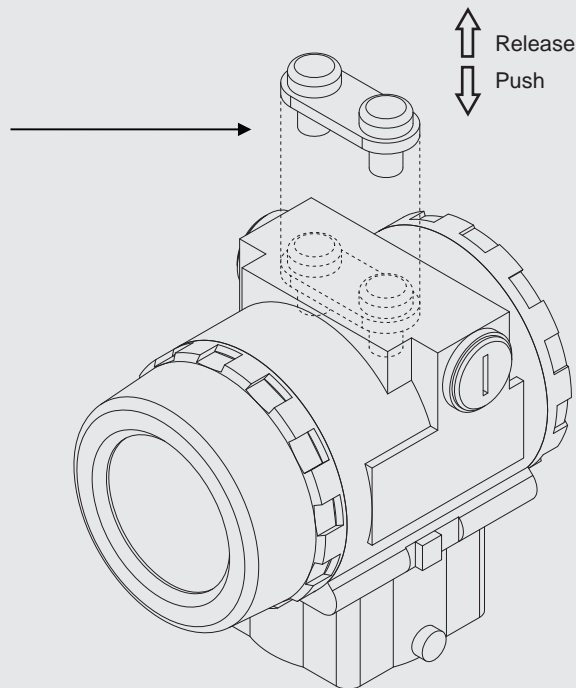

Other forms of
Process connector
1/2-NPT male thread

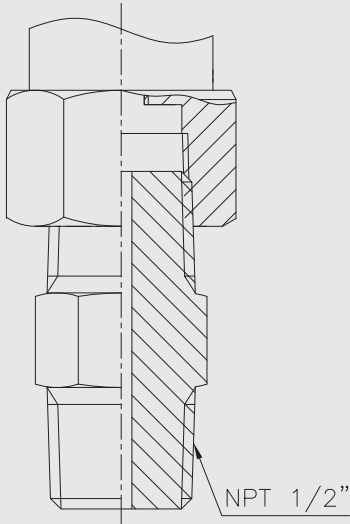

M20 x 1.5 male thread

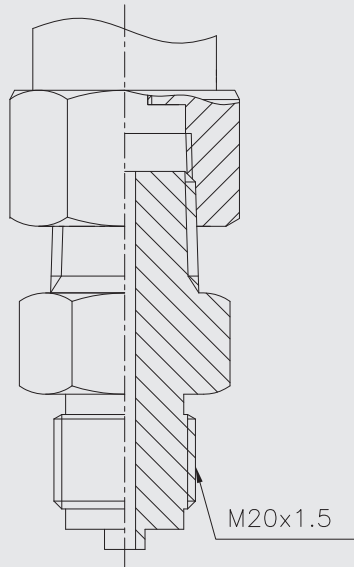

G 1/2 male thread

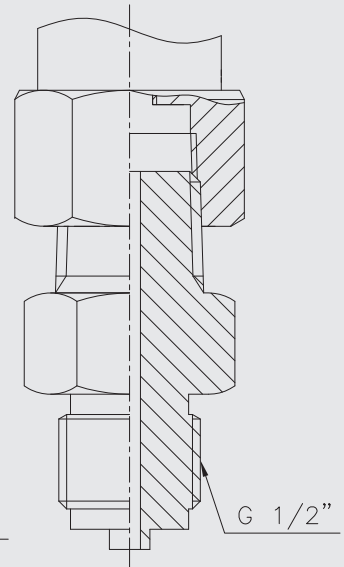

Vacuum Connection
DIN 28403 KF16 / ISO 2861

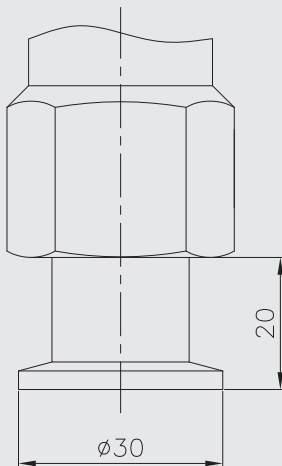

1/4-NPT male thread

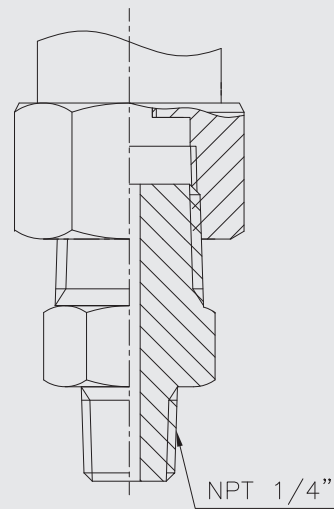

Electrical Connection Diagram

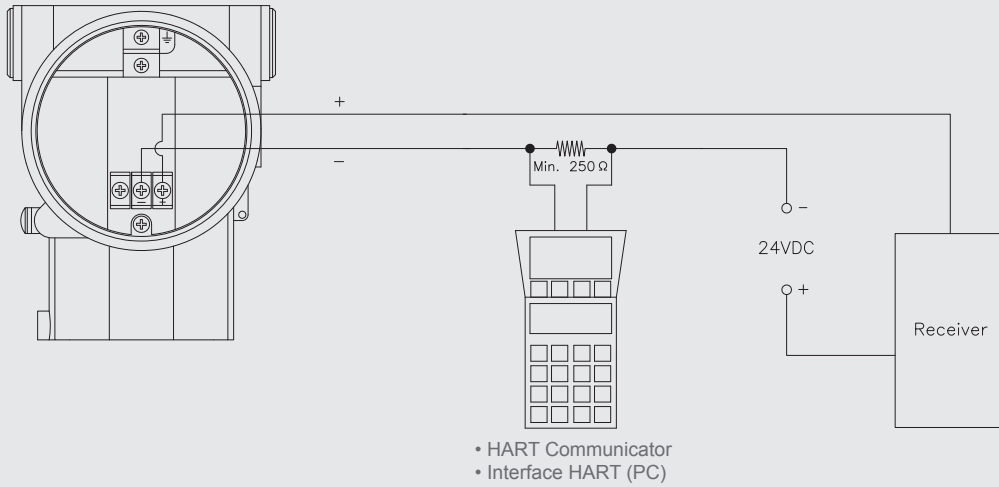

Terminal Configuration

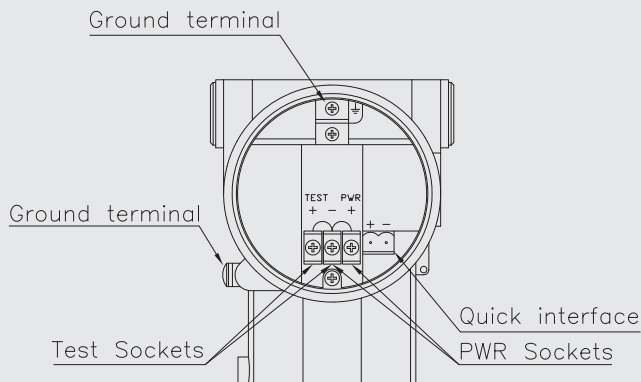

LCD Display

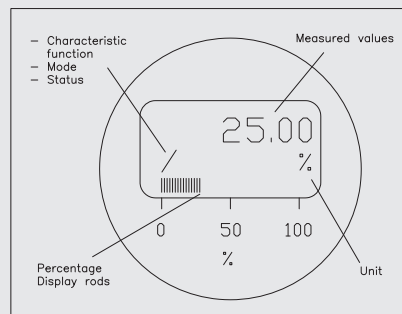

1. Base model**SMT2003** Absolute Pressure Transmitter**2. Measuring Span**

C 20 ~ 400 mbar (Only available accuracy 0.075 %)
D 25 ~ 2500 mbar
E 0.3 ~ 30 bar

3. Accuracy

5 0.05 % (Only D-E Sensor)
7 0.075 % (Only C-E Sensor)

4. Indication

N None
D Display (LCD)

5. Wetted parted materials (Seal diaphragm/Sensor body)

L 316L SS / 316SS
H Hastelloy C-276 / 316SS
G 316L SS with Gold Plated / 316SS

6. Filled by fluid

S Silicone oil
F Fluorinated oil

7. Explosion protection

N None
A Ex ia (ATEX)
B Ex ia (IECEX)
D Ex d (ATEX)
E Ex d (IECEX)
F Ex d (KCS)

8. Housing material

A Aluminium
S 316SS

9. Mounting bracket material

5 Carbon steel galvanized
4 304SS
0 None
9 Other

10. Process connection

F 1/2" NPT (Female)
M 1/2" NPT (Male) with Union
P M20 * 1.5 (Male) with Union
G G 1/2" (Male) with Union
K DIN 28403 KF16 / IOS 2861
Q 1/4" NPT (Male) with Union
Z Other

11*. Accessory

N None
V Manifold valve
O Other

* Note : Refer to A080's Specification and order valve(A080) separately. It's separate option.

1	2	3	4	5	6	7	8	9	10	11
SMT2003	C	5	N	L	S	N	A	5	F	N

Sample
ordering
code

WISE[®]

| SMT2003_11

Empty memo area for writing.